

CONFIDENTIAL INFORMATION: THIS DOCUMENT AND CONTAINED INFORMATION ARE THE PROPERTY OF RUSSTECH ENGINEERING COMPANY, INC. THE RECIPIENT, BY RECEIPT AND RETENTION HEREOF, ACKNOWLEDGES THAT THE INFORMATION RECEIVED IS CONFIDENTIAL, DEVELOPED OVER TIME AT SIGNIFICANT EXPENSE, AND THAT DISCLOSURE THEREOF TO THIRD PARTIES WILL CAUSE IRREPARABLE HARM TO RUSSTECH. THE RECIPIENT, BY THE RECEIPT AND RETENTION OF SUCH INFORMATION, AGREES TO MAINTAIN SUCH INFORMATION IN CONFIDENCE, TO NOT DISCLOSE IT TO THIRD PARTIES, AND TO RETURN IT, AND ALL COPIES OR DERIVATIVES THEREOF, IN ANY FORM, TO RUSSTECH, UPON REQUEST.

REVISION HISTORY						
ZONE	REV	DESCRIPTION	CHECKED BY	DATE	APPROVED BY	DATE
--	A	INITIAL RELEASE.	--	--	--	--

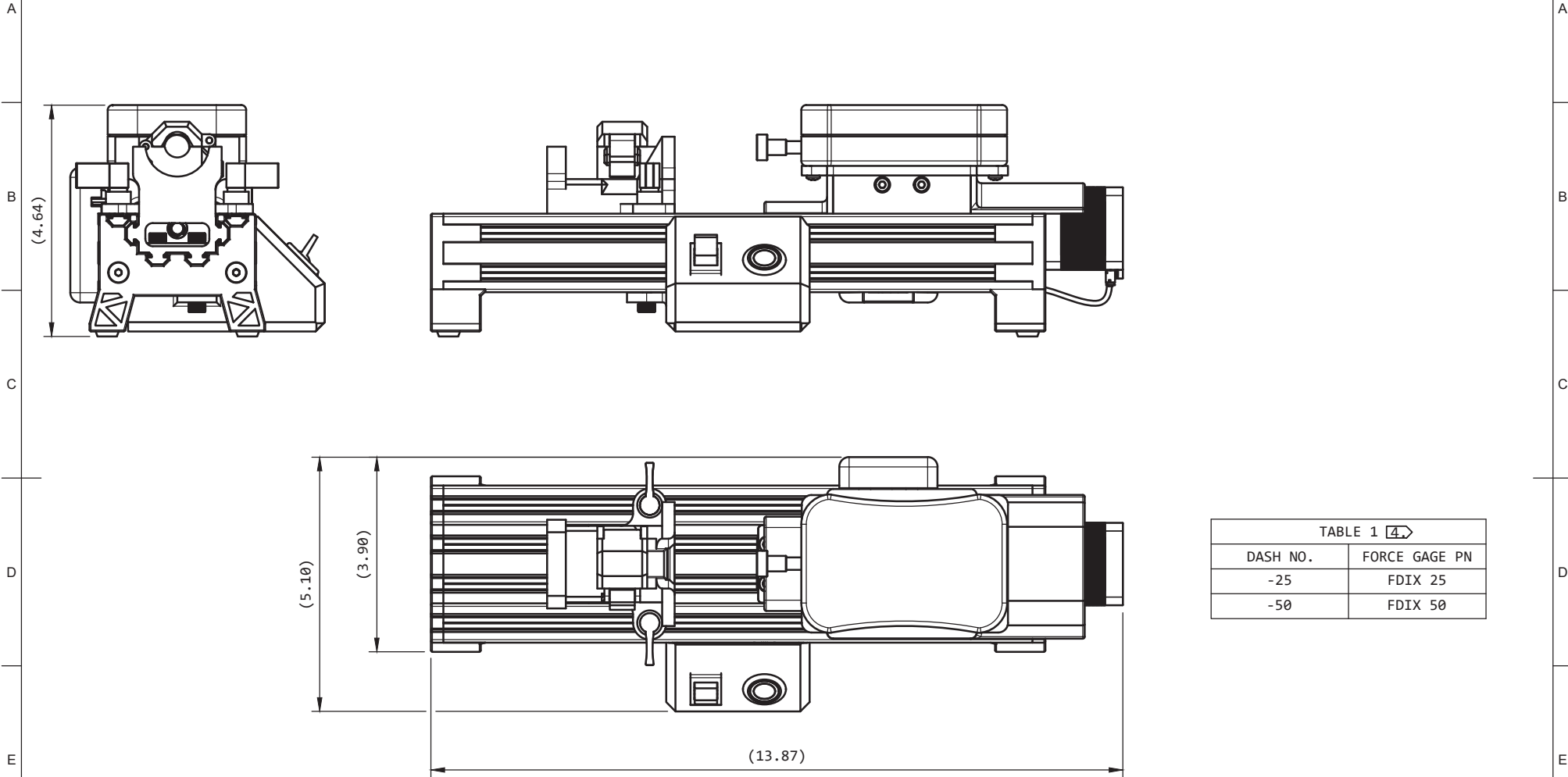

DASH NO.	FORCE GAGE PN
-25	FDIX 25
-50	FDIX 50

NOTES:

1. DIMENSIONS APPLY AFTER FINISH
2. PACKAGE TO PREVENT DAMAGE
3. ADDITIONAL ITEMS INCLUDED:
  - 3.1. ONE TEST PROBE (RTCRT-PCT101)
  - 3.2. ONE AC ADAPTOR (RTTP0046)
    - 3.2.1. INPUT: 100-240VAC, 50/60Hz, 1.5A
    - 3.2.2. OUTPUT: 24.0VDC, 2A
- DASH NUMBER AND FORCE GAGE PN CONTROLLED BY TABLE 1

TECHNICAL REFERENCE		RUSSTECH ENGINEERING COMPANY, INCORPORATED 4416 RUSSELL ROAD, SUITE A MUKILTEO, WA 98275, USA				
UNLESS OTHERWISE SPECIFIED DIMENSIONS ARE IN DECIMAL INCHES WITH METRIC IN BRACKETS.  TOLERANCES ARE:  .X ± .1 .XX ± .03 .XXX ± .010 ANGLES ± .5°  REMOVE ALL BURRS & SHARP EDGES	APPROVALS	DATE	TITLE			
	DRAWN BY B. LEBSON	10/25/22	AUTOMATED TOOL TESTER			
	CHECKED BY Wm Bryon Duncan	11/15/22	SIZE	CAGE CODE	DRAWING NUMBER	REV.
	ENGINEER Ben Lebson	11/15/22	A3	1EG24	RTTE0001-S	A
APPROVED BY Brian Collins	11/15/22	SCALE	AUTODESK-FUSION	DEPARTMENT SALES	SHEET 1/1	
		1:2				